



DNH

HEAD OFFICE, NORWAY
DNH AS

Phone..... + 47 35 98 56 00
 Fax..... + 47 35 98 56 10
 E-mail..... dnh@dnh.no
 Web-Site..... www.dnh.no

ENGLAND
DNH WW Ltd

Phone..... + 44 1908 275 000
 Fax..... + 44 1908 275 100
 E-mail..... dnh@dnh.co.uk

GERMANY
DNH GmbH

Phone... + 49 040 6569 30-0
 Fax..... + 49 040 6569 30-30
 E-mail..... dnh@dnh.de

SAFE-561(T)

USA
DNH Speakers Inc

Phone..... + 1 484 494 5790
 Fax..... + 1 484 494 5793
 E-mail..... dnh@dnhspeakers.com

ISO 9001 CERTIFIED

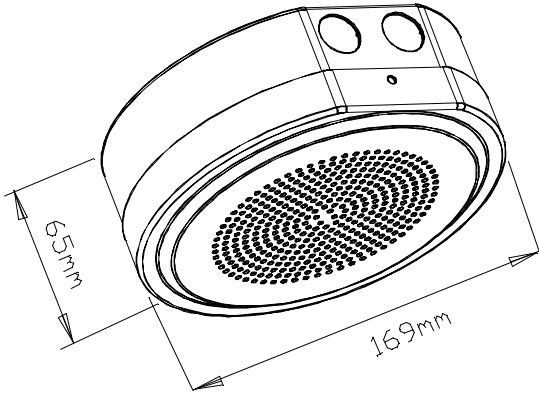

2+2 x M20 knock outs

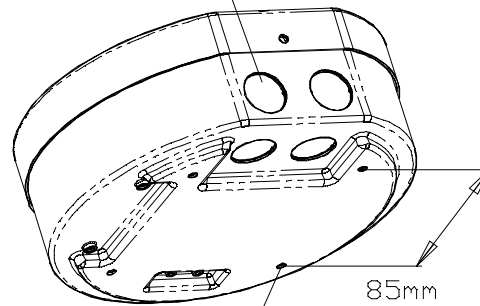

4 x ø4mm mounting holes

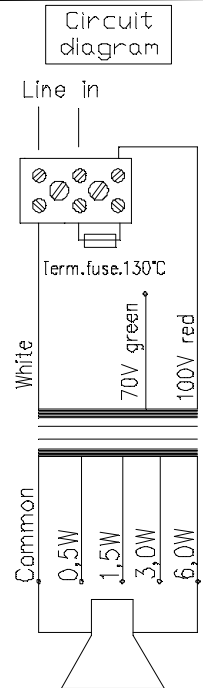

Sound pressure levels at 1W/1m

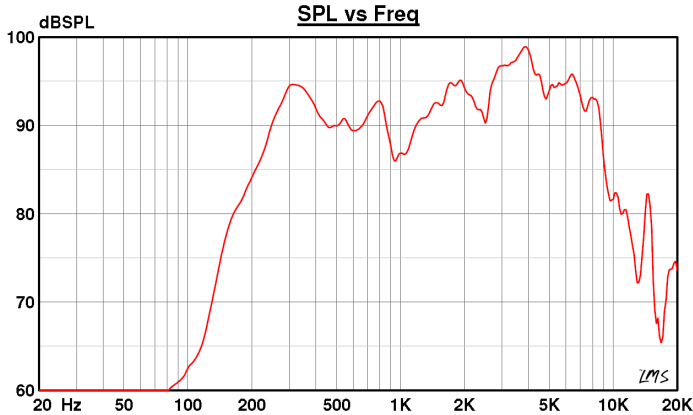

Specifications

Material / Color	Steel / White Ral 9010
Mounting	Four screws
Termination	Ceramic terminals
Weight w/transformer	1,2 kg
IP-rating	30
Max. / min. amb. temp	110°C / -20°C
Rated / max. power	6 W / 6 W
SPL 1W/1m	90 dB
SPL rated power	97 dB
Effective freq. range	180 – 13000 Hz
Dispersion (-6dB) 1kHz / 4kHz	187° / 77°
Directivity factor, Q	1,9
Options	Impedances, colors, labels

Installation, Operation and Maintenance Procedures

- Mount cabinet to wall/ceiling with 4 suitable screws. Lead cable through cable gland.
- If 70V, replace red cable with the green cable in the terminal.
- Connect to terminal and select required tapping.
- Fasten the front part to the cabinet with 2 provided screws.
- For optimum performance, always use the correct voltage / power and operate within the frequency limits as stated.
- Transformer according to British standard 5839.
- Do not open loudspeaker when energized.
- This loudspeaker is supplied with a 2 year warranty against defective workmanship.

DNH reserves the right to alter specifications without notice

