



# DNH

HEAD OFFICE, NORWAY

**DNH AS**

Phone..... + 47 35 98 56 00

Fax..... + 47 35 98 56 10

E-mail..... dnh@dnh.no

Web-Site..... www.dnh.no

ENGLAND

**DNH WW Ltd**

Phone..... + 44 1908 275 000

Fax..... + 44 1908 275 100

E-mail..... dnh@dnh.co.uk

GERMANY

**DNH GmbH**

Phone... + 49 040 6569 30-0

Fax..... + 49 040 6569 30-30

E-mail..... dnh@dnh.de

## VES-661(T)

USA

**DNH Speakers Inc**

Phone..... + 1 484 494 5790

Fax..... + 1 484 494 5793

E-mail..... dnh@dnhspeakers.com

ISO 9001 CERTIFIED

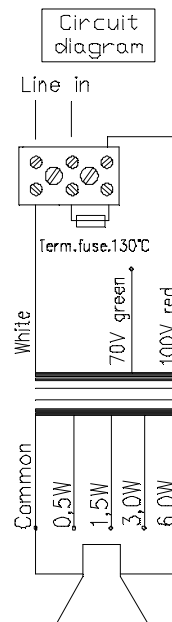
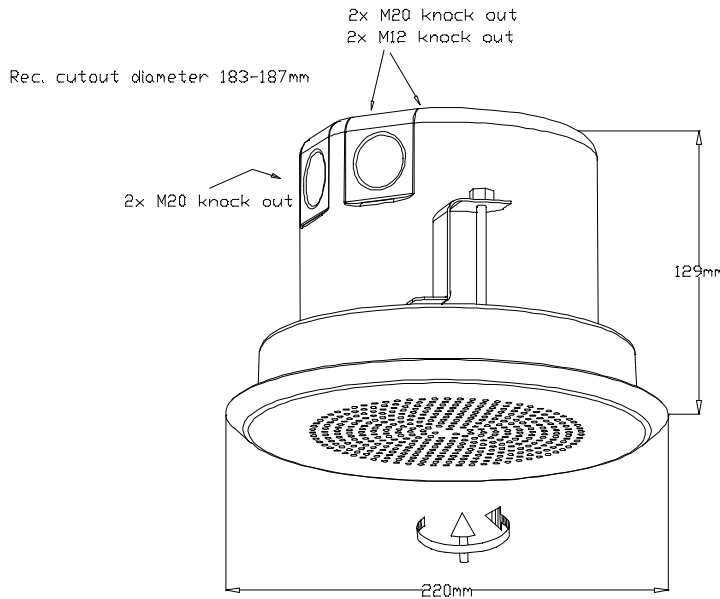

### Sound pressure levels at 1W/1m

#### SPL vs Freq



### Specifications

Material / Color	Steel / White RAL 9010
Mounting	3 screws
Termination	Ceramic terminals
Weight	1,9 kg
IP-rating	N/A
Max. / min. amb. temp	110°C / -20°C
Standard version	100 V transformer
Rated / max. power	6 W / 10 W
SPL 1W/1m	92 dB
SPL rated power	98 dB
Effective freq. range	130 – 12000 Hz
Dispersion (-6dB) 1kHz / 4kHz	N/A
Options	Impedances, colors, labels

### Installation, Operation and Maintenance Procedures

- Fitted with a two way 6" element.
- Install the steel box into the cut-out hole turning the screws connected to the three hooks, screw clockwise until the ring is fixed to the ceiling.
- Lead cable through cable gland and connect to terminal.
- If 70V, replace red cable with the green cable in the terminal.
- Turn the grill gently clockwise within the ring until it stops.
- Hooks can be mounted both ways to fit the roof thickness.
- For optimum performance, always use the correct voltage / power and operate within the frequency limits as stated.
- Transformer compliant to British standard 5839.
- Do not open loudspeaker when energized.
- This loudspeaker is supplied with a 2 year warranty against defective workmanship.

DNH reserves the right to alter specifications without notice

